



ENVIRONMENTAL TECHNOLOGY

# CYCL™ Cyclone Separator



## FEATURES

316 S/S STANDARD CONSTRUCTION  
(DUPLEX OPTION AVAILABLE)

LARGE INTERNAL CLEARANCES

WORKS FROM PUMP DISCHARGE

## BENEFITS

- HARD WEARING MATERIALS OF CONSTRUCTION GUARANTEE LONG PRODUCT LIFE IN ABRASIVE INDUSTRIES

- RESTRICTS THE POTENTIAL FOR CLOGGING

- DOES NOT REQUIRE A WATER SOURCE FOR SEAL FLUSH FLUID





# CYCL™ - Operation

The CYCL™ is designed to separate heavy particles from the product liquid. The clean fluid is ideal for use as flush fluid, improving conditions at seal faces. The separated particles drain back into the sealed product. The benefit is a reliable and low-cost sealing system for heavy product particle applications, which does not require an independent flush supply.

KEY - Piping diagram schematic

ITEM	DESCRIPTION
A	Mechanical Seal
B	Dirty Product Liquid Pressure Feed
C	Cyclone Separator
D	Clean Product Liquid (Mechanical Seal Flush Fluid)
E	Dirty Product Liquid Return to Pump Suction

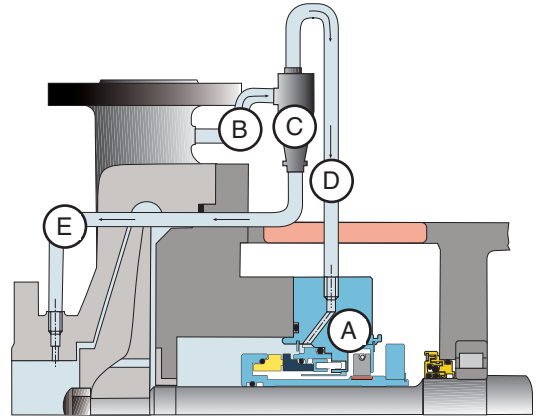

# CYCL™ - Items and Sizing

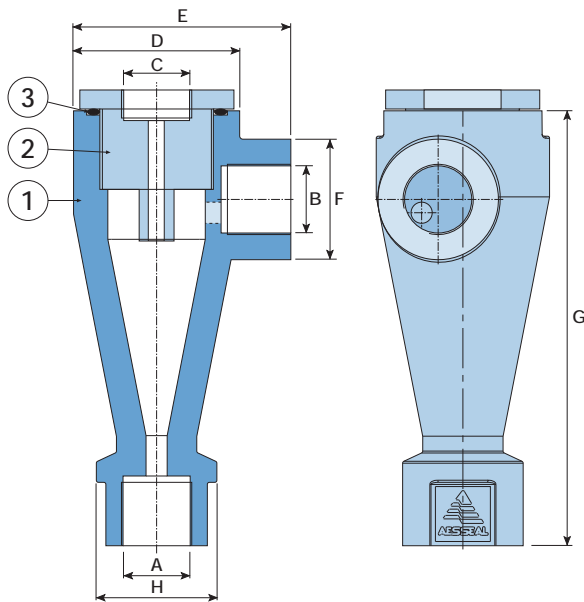

CYCL™ - Parts List

ITEM	DESCRIPTION
1	Cyclone Separator Body
2	Hex. Reducing Bush
3	Dowty Washer

CYCL™ - Key interface dimensions, mm (inches)

Style	Ø A, B, C,	ØD	E	F	G	H
316 SS	1/2" NPT	48mm	66mm	35mm	118mm	35mm
Duplex		1.89"	2.60"	1.38"	4.65"	1.38"
316 SS	1" NPT	82mm	106.5mm	57mm	220mm	57mm
Duplex		3.20"	4.09"	2.20"	8.7"	2.20"

THIS DOCUMENT IS DESIGNED TO PROVIDE DIMENSIONAL INFORMATION AND AN INDICATION OF AVAILABILITY. FOR FURTHER INFORMATION AND SAFE OPERATING LIMITS CONTACT OUR TECHNICAL SPECIALISTS AT THE LOCATIONS BELOW.



INVESTOR IN PEOPLE



USE DOUBLE MECHANICAL SEALS WITH HAZARDOUS PRODUCTS. ALWAYS TAKE SAFETY PRECAUTIONS:

- GUARD YOUR EQUIPMENT
- WEAR PROTECTIVE CLOTHING



**UK Sales & Technical advice:**  
 AESSEAL plc  
 Mill Close  
 Templeborough  
 Rotherham  
 S60 1BZ  
 United Kingdom  
 Telephone: +44 (0) 1709 369966  
 Fax: +44 (0) 1709 720788  
 E-mail: seals@aesseal.com  
 Internet: http://www.aesseal.com

Distributed by:

---

**Our Purpose:** *'To give our customers such exceptional service that they need never consider alternative sources of supply.'*

**USA Sales & Technical advice:**  
 AESSEAL Inc.  
 355 Dunavant Drive  
 Rockford  
 TN. 37853  
 USA  
 Telephone: +1 865 531 0192  
 Fax: +1 865 531 0571  
 E-mail: usa@aesseal.com

**Systems Sales & Technical advice:**  
 AESSEAL (MCK) Ltd.  
 139A Hillsborough Old Road  
 Lisburn  
 N.Ireland  
 BT27 5QE  
 Telephone: +44 (0) 28 9266 9966  
 Fax: +44 (0) 28 9266 9977  
 Tel/Fax Hotline: +44 (0) 28 9266 9988  
 E-mail: MCK@aesseal.co.uk

ALL SIZES ARE SUBJECT TO MANUFACTURING TOLERANCES. WE RESERVE THE RIGHT TO MODIFY SPECIFICATIONS AT ANY TIME.